

Introduction to Atmospheric Flight

Dr. Guven

Aerospace Engineer (P.hD)

What is Atmospheric Flight?

- There are many different ways in which Aerospace engineering is associated with atmospheric flight concepts.
- Majority of the flight vehicles are atmospheric in nature such as passenger planes, military jets, cargo planes, balloons, helicopters and other similar craft.
- In addition, almost all of the space craft and rockets will pass through the atmosphere in launching stage or in the landing stage
- For probes landing on Mars and other planets , the atmospheric landing principles would apply.

What are the Parameters in an Atmospheric Flight?

- Mostly atmospheric flight is concerned with aerodynamics which studies the flow of gases and air under various conditions.
- On low density atmosphere (near the space, above 400 km) you will have molecular flow while below that level you will have continuum flow.
- Knowing the properties of the gas will help you determine the parameters of atmospheric flight

Physical Quantities of Flowing Gas

- To understand aerodynamics and the concept of atmospheric flight, it is essential to understand the physical quantities of flowing gases. These properties include:
 - **Pressure**
 - - **Density**
 - - **Temperature**
 - - **Flow Velocity**
 - - **Stream Lines**

Pressure

- Pressure is the most dominant aerodynamic force that acts upon atmospheric flight.
- Pressure is defined as the normal force per unit area exerted on a surface due to the time rate of the change of momentum of gas molecules impacting on the surface.
- Pressure is shown as Newton's per meter square or as atm (atmosphere)

$$p = \lim_{dA \rightarrow 0} \left(\frac{dF}{dA} \right)$$

dA = elemental area at B

dF = force on one side of dA due to pressure

Density

- The density of a substance is the mass of a substance per unit volume.
- Hence, the unit for density is shown as kg / m^3
- Density is a point by point property (just like pressure) and it can change at different points in the flow of the gas.

$$\rho \equiv \lim_{dv \rightarrow 0} \frac{dm}{dv}$$

dv = elemental volume around B

dm = mass of fluid inside dv

Temperature

- Temperature is the third most important physical quantity or flow parameter when it comes to describing flows.
- Temperature is defined as the measure of the average kinetic energy of the particles in the gas.
- Hence, a gas particle that is moving faster will have a higher kinetic energy and as a result it will have a higher temperature compared to a particle that is moving slowly.
- Especially in high speed flows, temperature can be the most important property in the flow.

Flow Velocity

- Fluid is a squishy substance as compared to a solid. Hence, some parts of the fluid or gas may be flowing at a different rate of speed as compared to other parts.
- Thus, we consider flow velocity as a point property that can vary from point to point just like pressure, density and temperature.
- Flow velocity at any point B is the velocity of an infinitesimally small fluid element as it sweeps through B

Streamlines

- While the flow is steady, the moving element in a fluid is seen to trace a fixed path in space and this path is called the streamline of the flow.
- By sketching the streamlines of the flow, we can understand the flow around various objects

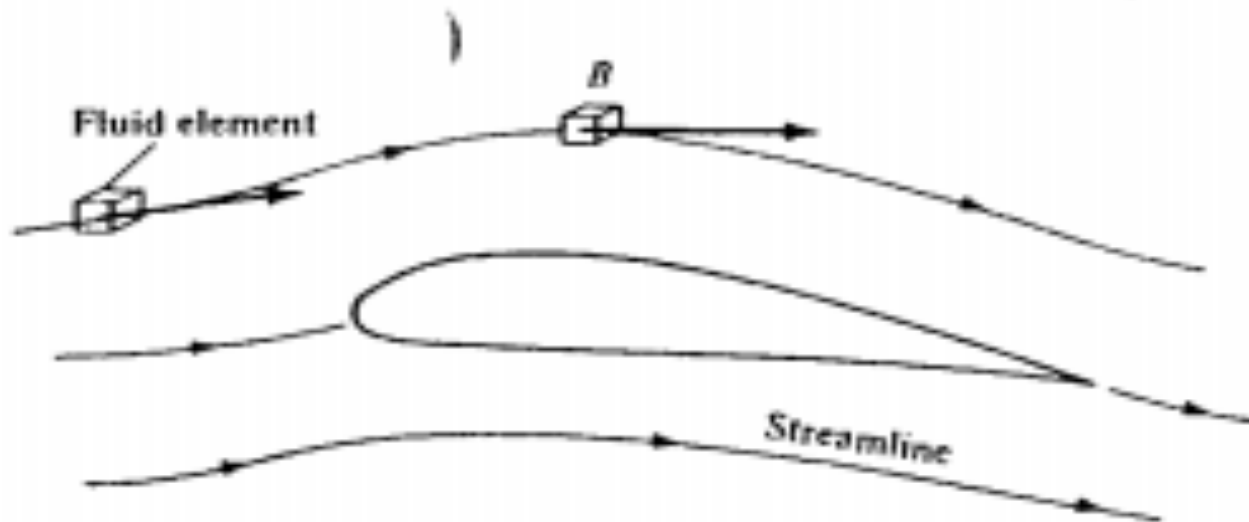

Flow Field

- By knowing the pressure, density, temperature and velocity at all points in the flow, we can easily determine the flow field around an object.
- Velocity of the flow field ahead of the solid object is called the free stream velocity.

Aerodynamic Forces

- Aerodynamic forces are caused by two basic forces that act upon them which are:
 - Pressure distribution on the surface
 - shear stress (friction) on the surface
- No matter how complex the flow field may be and no matter how complex the shape of the body, the only way a nature can exert an aerodynamic force is either by pressure or shear stress distribution on the body.

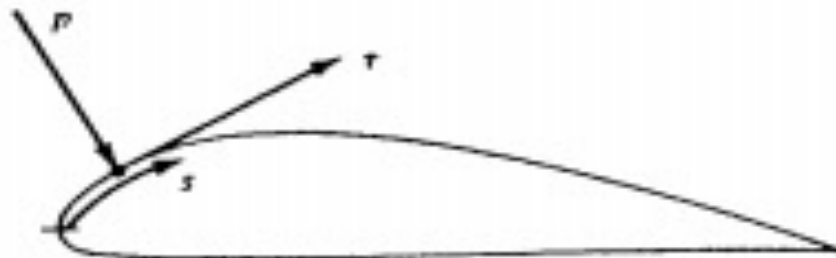

$p = p(s)$ = surface pressure distribution
 $\tau = \tau(s)$ = surface shear stress distribution

Aerodynamic Force Distribution on a Solid Body

- If we take the force distributions of pressure and shear stress around a solid body, we will get two forces of Lift and Drag which will create a single vectored force R on the body.

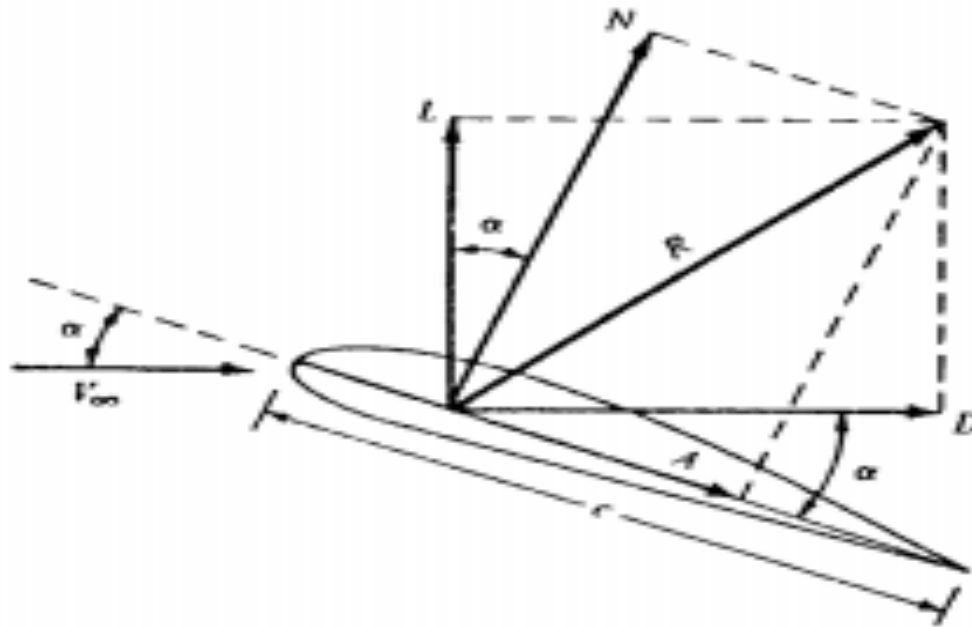

Terms for Aerodynamic Forces

- Freestream velocity is the flow velocity in the far field of the flow.
- Chord c is the linear distance from the trailing edge to the leading edge of the body.
- α is the angle of attack between the c and the freestream velocity.

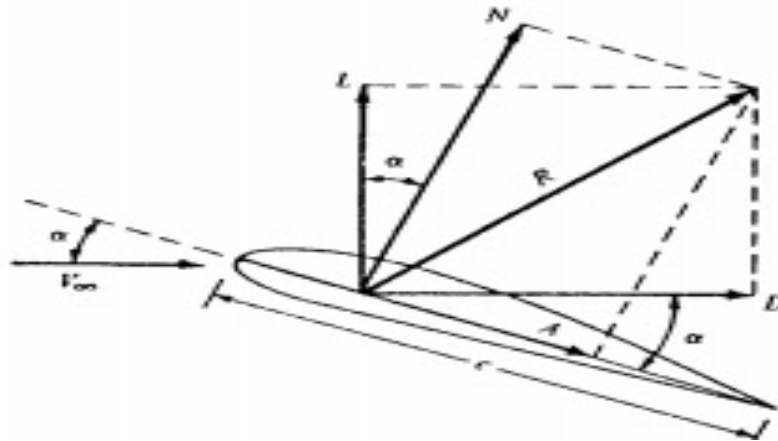

L = lift = component of R perpendicular to V_∞

D = drag = component of R parallel to V_∞

Aerodynamic Coefficients

Dynamic pressure

$$q_{\infty} = \frac{1}{2} \rho_{\infty} V_{\infty}^2$$

Lift coefficient

$$C_L = \frac{L}{q_{\infty} S}$$

Drag coefficient

$$C_D = \frac{D}{q_{\infty} S}$$

Normal force coefficient

$$C_N = \frac{N}{q_{\infty} S}$$

Axial force coefficient

$$C_A = \frac{A}{q_{\infty} S}$$

Moment coefficient

$$C_M = \frac{M}{q_{\infty} S l}$$

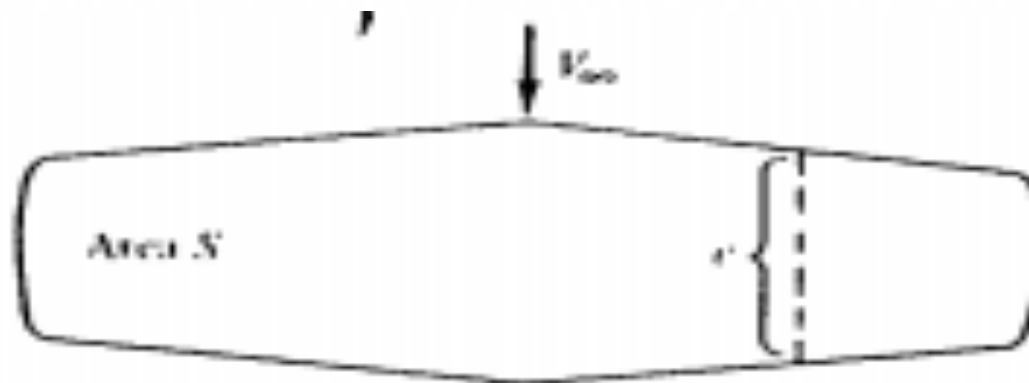

S = planform area
 $l = c$ = chord length

Control Surfaces

- Control Surfaces are parts of the plane that control its aerodynamic stability
- **Flaps** are used to increase the lift force on the plane
- **Ailerons** are control surfaces that control the rolling motion of the plane. Upward aileron will decrease lift and cause the plane to lean in that direction
- **Rudder** is a control surface that can turn the nose of the plane to the right or left (yawing)
- **Elevator** will turn the nose up and down
- **Slats** are used to increase lift force on the plane

Anatomy of an Airplane

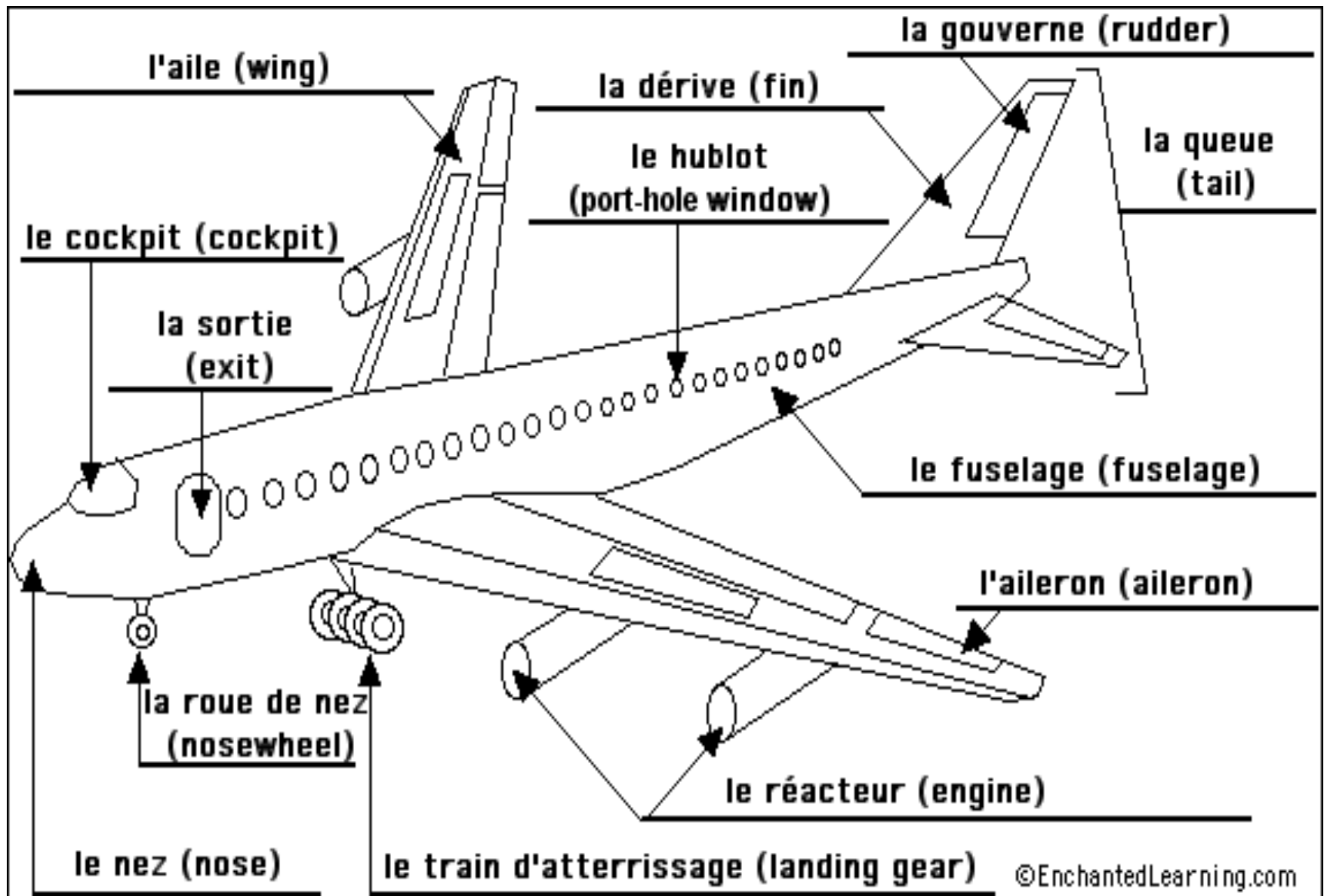

Aeronautical Dynamics

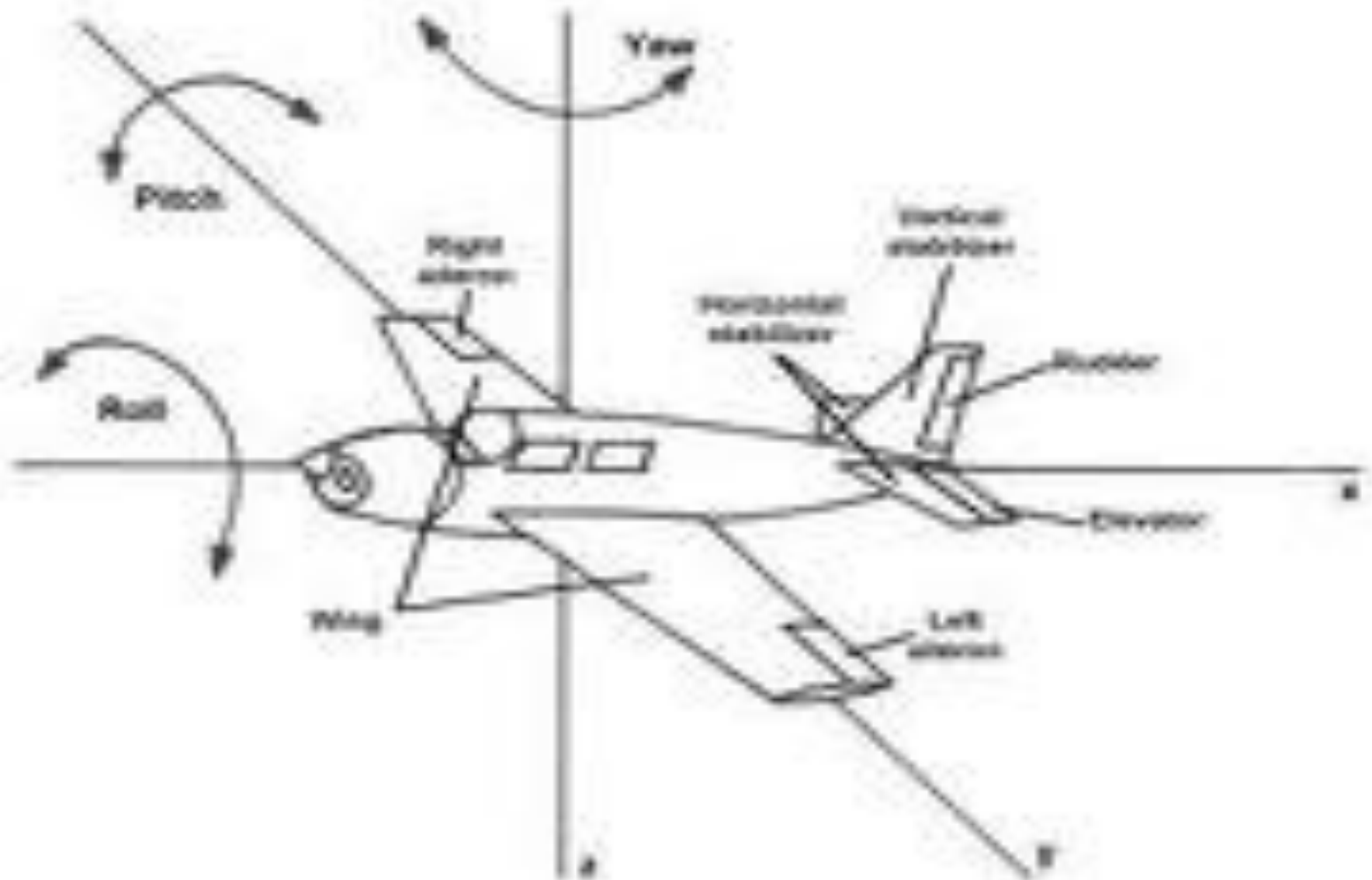

Dynamics

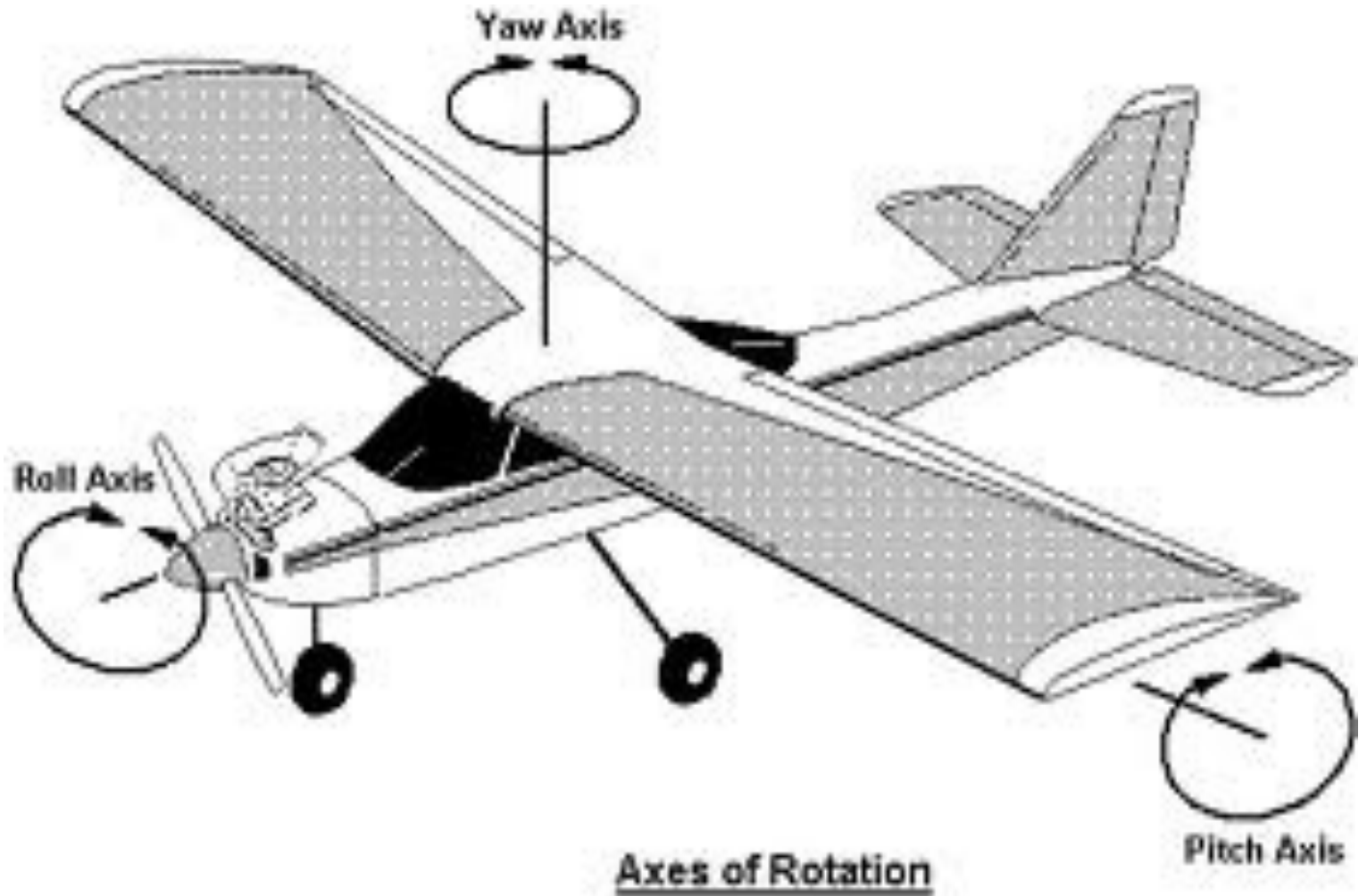

Airfoil

- Any section of the wing cut by a plane parallel to the xz plane is called an airfoil.

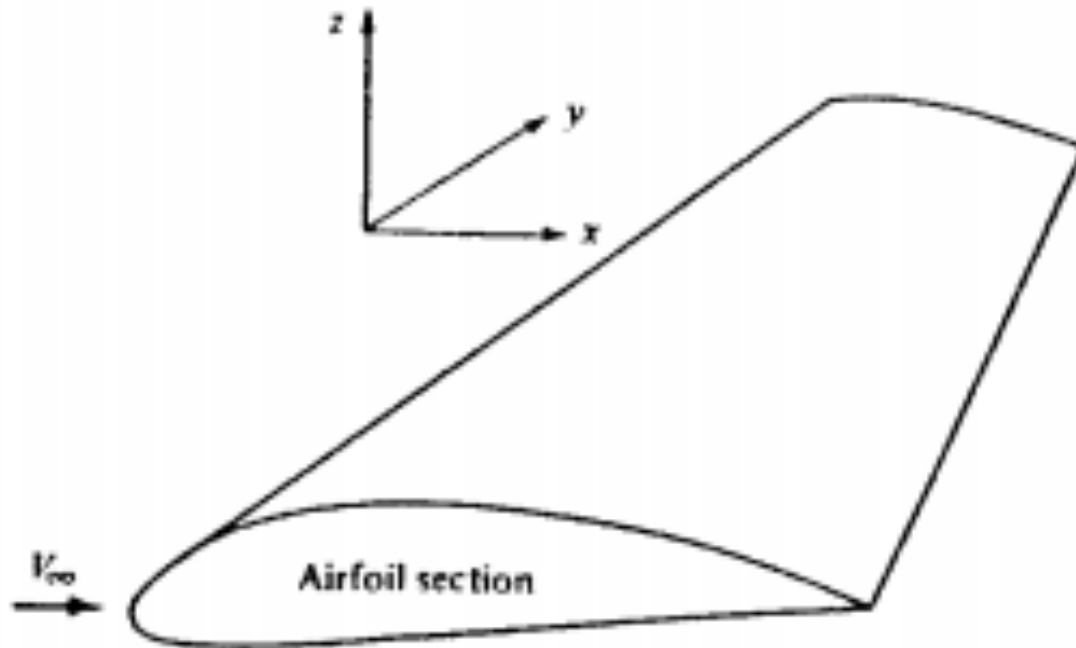

Airfoil Nomenclature

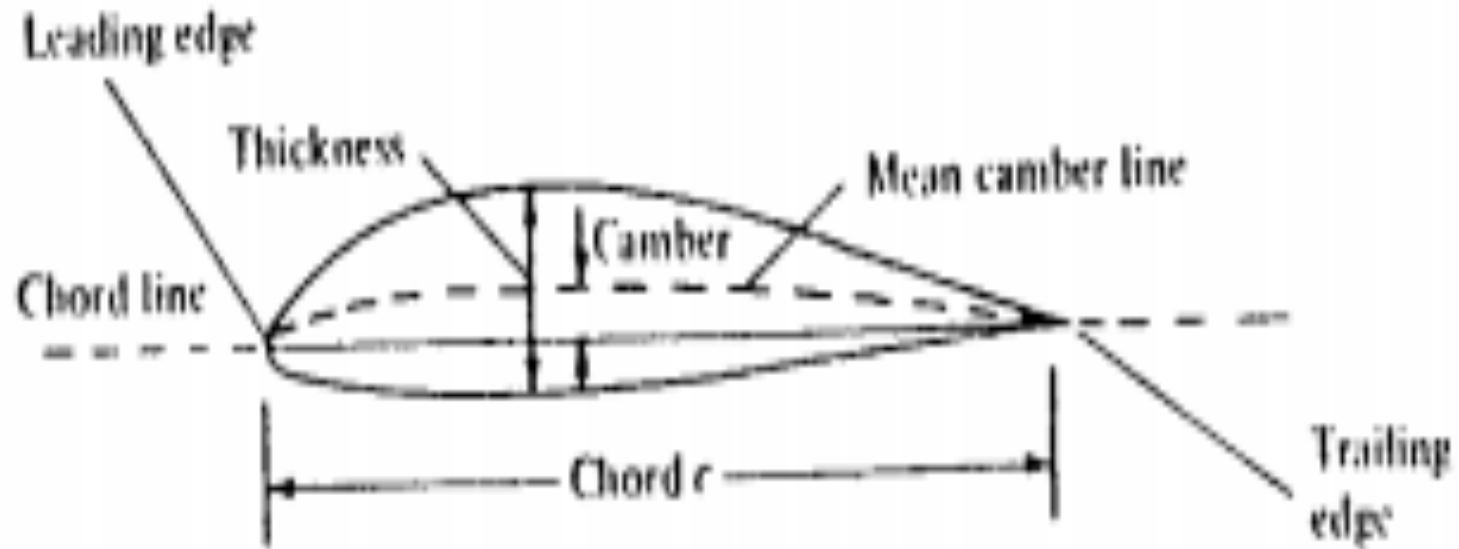

NACA Numbering System

The NACA identified different airfoil shapes with a logical numbering system. For example, the first family of NACA airfoils, developed in the 1930s, was the "four-digit" series, such as the NACA 2412 airfoil. Here, the first digit is the maximum camber in hundredths of chord, the second digit is the location of maximum camber along the chord from the leading edge in tenths of chord, and the last two digits give the maximum thickness in hundredths of chord. For the NACA 2412 airfoil, the maximum camber is $0.02c$ located at $0.4c$ from the leading edge, and the maximum thickness is $0.12c$. It is common practice to state these numbers in percent of chord, i.e.,

NACA Numbering System for Airfoils

The second family of NACA airfoils was the "five-digit" series, such as the NACA 23012 airfoil. Here, the first digit when multiplied by $\frac{1}{2}$ gives the design lift coefficient[†] in tenths, the next two digits when divided by 2 give the location of maximum camber along the chord from the leading edge in hundredths of chord, and the final two digits give the maximum thickness in hundredths of chord. For the NACA 23012 airfoil, the design lift coefficient is 0.3, the location of maximum camber is at 0.15c, and the airfoil has 12 percent maximum thickness.

Usage of Airfoils in Planes

As a matter of interest, the following is a short partial listing of airplanes in service in 1982 which use standard NACA airfoils.

Airplane	Airfoil
Beechcraft Sundowner	NACA 63A415
Beechcraft Bonanza	NACA 23016.5 (at root) NACA 23012 (at tip)
Cessna 150	NACA 2412
Fairchild A-10	NACA 6716 (at root) NACA 6713 (at tip)
Gates Learjet 24D	NACA 64A109
General Dynamics F-16	NACA 64A204
Lockheed C-5 Galaxy	NACA 0012 (modified)

In addition, many of the large aircraft companies today design their own special-purpose airfoils; e.g., the Boeing 727, 737, 747, 757, and 767 all have specially designed Boeing airfoils. Such capability is made possible by modern airfoil design computer programs utilizing either panel techniques or direct numerical finite-difference solutions of the governing partial differential equations for the flow field. (Such equations

Airfoil and Angle of Attack Example

- Each airfoil has a unique response to the angle of attack

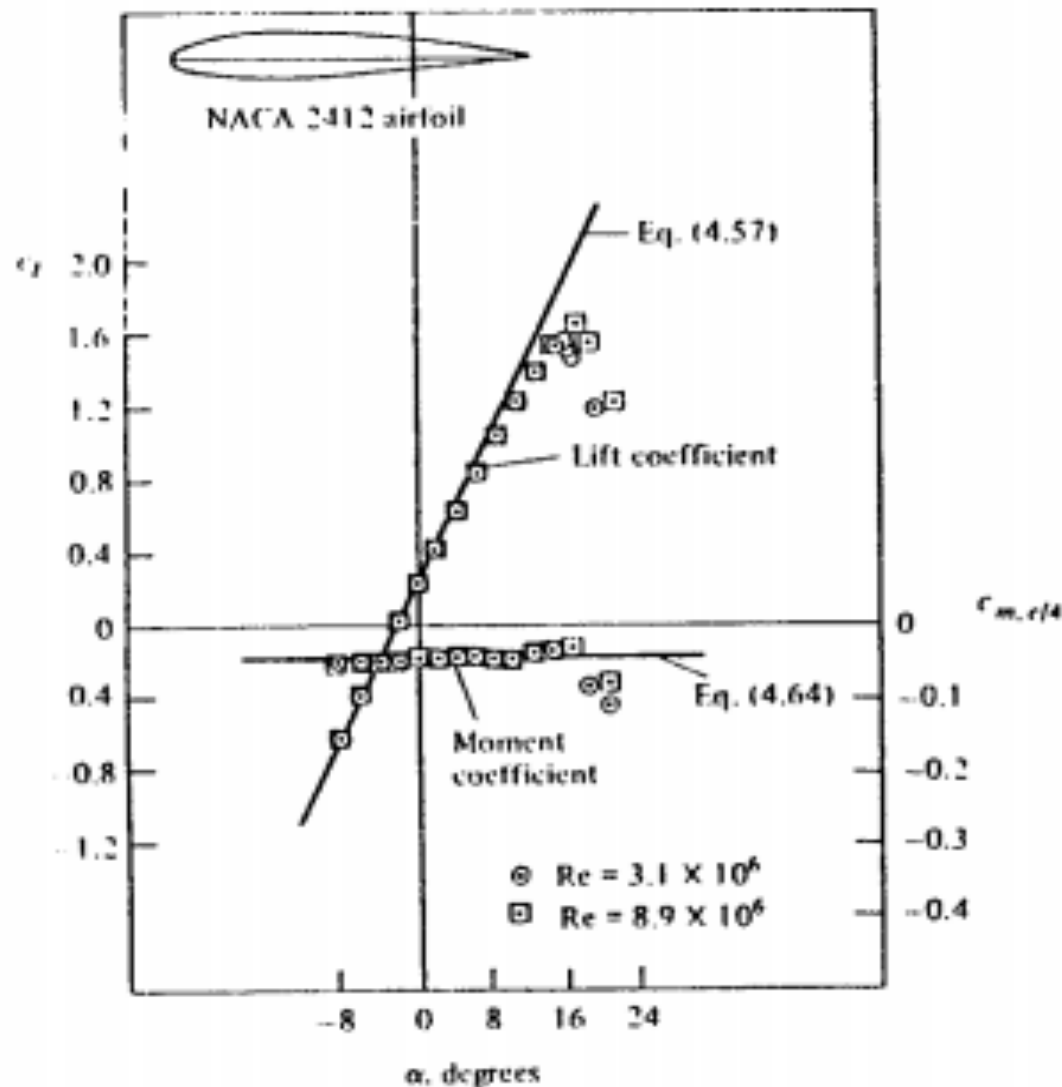



(a)



(b)



(c)

Figure 4.13 The development of steady flow over an airfoil; the airfoil is impulsively started from rest and attains a steady velocity through the fluid. (a) A moment just after starting. (b) An intermediate time. (c) The final steady flow. (From Prandtl and Tietjens, Ref. 8.)